

# Testing psychometric properties of Shared Decision Making Questionnaire – Physician Version (SDM-Q-Doc) in an Italian real-world psychiatric clinical sample

RENATO DE FILIPPIS<sup>1</sup>, MATTEO ALOI<sup>1,2</sup>, SALVATORE REINA<sup>1</sup>, ANTONIA CANTAVENARA<sup>1</sup>, LUCA STEARDO JR<sup>1</sup>, PASQUALE DE FAZIO<sup>1</sup>, CRISTINA SEGURA-GARCIA<sup>3</sup>

<sup>1</sup>Psychiatry Unit, Department of Health Sciences, University Magna Graecia of Catanzaro, Italy; <sup>2</sup>Department of Clinical and Experimental Medicine, University of Messina, Italy; <sup>3</sup>Psychiatry Unit, Department of Medical and Surgical Sciences, University Magna Graecia of Catanzaro, Italy.

**Summary. Objectives.** The Shared Decision Making Questionnaire-Physician Version (SDM-Q-Doc) is the main tool assessing SDM relationship between patient and physician using the clinician viewpoint. It is reliable in all medical fields, and the validation of its Italian version was still missing. Our aim was to validate the Italian version of the SDM-Q-Doc in a clinical sample of patients suffering from severe mental illness. **Methods.** We approached 369 patients affected by major psychiatric disorders (including schizophrenia spectrum disorders, affective disorders and eating disorders) in a real-world outpatient clinical setting. We run the Confirmatory Factor Analysis (CFA) to test the SDM-Q-Doc structure. We calculated the correlations between the SDM-Q-Doc and the Observing Patient Involvement (OPTION) scale, used as comparing test, and McDonald  $\omega$  coefficient to measure convergent validity and internal consistency respectively. **Results.** We reached a response rate of 93.2% (344 final participants). The CFA showed a very good fit compared of the Italian version of SDM-Q-Doc ( $\chi^2/df=3.2$ , CFI=.99, TLI=.99, RMSEA=.08, SRMR=.04). We found several correlations between the SDM-Q-Doc and OPTION scale supporting a robust SDM-Q-Doc construct validity, while internal consistency of the scale was McDonald  $\omega$  coefficient .92. Further, inter-item correlations ranged from .390 to .703, with a mean of .556. **Conclusions.** This study confirms the suitability of the Italian version of SDM-Q-Doc, with good reliability and soundness even when compared to other languages validated versions and to OPTION scale. SDM-Q-Doc represents an easy-to-use physician-centered measure to assess patients' involvement in medical decision-making, well performing in the Italian-speaking population.

**Key words.** Patient involvement, physicians' perspective, psychometrics, questionnaires, shared decision making, validation study.

*Valutazione delle proprietà psicometriche dello Shared Decision Making Questionnaire – Physician Version (SDM-Q-Doc) in un campione clinico psichiatrico italiano nel mondo reale.*

**Riassunto. Scopo.** Lo Shared Decision Making Questionnaire - Physician Version (SDM-Q-Doc) è lo strumento psicometrico principale per valutare l'alleanza terapeutica dal punto di vista del clinico. Esso è utilizzabile in tutte le discipline mediche, ma la validazione della sua versione italiana non era ancora disponibile. Il nostro obiettivo è stato quello di validare la versione italiana dello SDM-Q-Doc in un campione clinico di pazienti affetti da gravi disturbi psichiatrici. **Metodi.** Abbiamo approcciato 369 pazienti ambulatoriali affetti da disturbi psichiatrici maggiori (inclusi disturbi dello spettro della schizofrenia, disturbi affettivi e disturbi alimentari). Abbiamo eseguito l'analisi fattoriale di conferma (CFA) per testare la struttura dello SDM-Q-Doc. Abbiamo inoltre calcolato le correlazioni esistenti tra la scala SDM-Q-Doc e l'Observing Patient Involvement (OPTION), utilizzata come test di confronto, e il coefficiente  $\omega$  di McDonald per misurare rispettivamente la validità convergente e la coerenza interna. **Risultati.** Abbiamo ottenuto un tasso di risposta del 93,2% (344 partecipanti finali). Il CFA ha mostrato un ottimo adattamento rispetto alla versione italiana dello SDM-Q-Doc ( $\chi^2/df=3,2$ , CFI=.99, TLI=.99, RMSEA=.08, SRMR=.04). Abbiamo identificato diverse correlazioni tra lo SDM-Q-Doc e l'OPTION supportando una robusta validità della struttura dello SDM-Q-Doc, mentre la coerenza interna della scala ha ottenuto un coefficiente  $\omega$  di McDonald di .92. Inoltre, le correlazioni tra i quesiti variavano da ,390 a ,703, con una media di .556. **Conclusioni.** Questo studio conferma la validità della versione italiana dello SDM-Q-Doc, con buona affidabilità e solidità anche rispetto alle versioni validate in altre lingue e alla scala OPTION. Lo SDM-Q-Doc rappresenta una misura incentrata sul punto di vista del medico e di facile utilizzo per valutare il coinvolgimento dei pazienti nel processo decisionale clinico, ben performante anche nella popolazione di lingua italiana.

**Parole chiave.** Coinvolgimento del paziente, decisione clinica condivisa, prospettiva del medico, psicomètria, questionari, studio di validazione.

## Introduction

Shared decision making (SDM) refers to a complex interplay between patient and clinician, which

occurs within the context of a composite environmental interaction aiming to reach a mutual medical decision<sup>1,2</sup>. The modern concept of SDM tries to overcome the old fashioned "paternalistic approach",

which dominated medical relationships for decades, with physicians ruling over patients regarding clinical choices. Only in recent years there has been a fresh and modern move toward increased patient involvement, implementing SDM in many specialties all over the world<sup>3</sup>.

Indeed, patients are more and more encouraged to communicate their medical preferences, consider the cost/benefit ratio of their choices, and select the option that best fits their personal predispositions<sup>4</sup>. In this context, SDM represents a joint process which helps to ensure that treatment decisions reflect patient inclinations with the goal to improve patient care experiences and overall treatment outcomes<sup>5,6</sup>. Therefore, SDM is becoming an essential point of health care quality and should be included into the principles of good clinical practice and international guidelines for all medical and surgery specialties<sup>7,8</sup>.

Measuring SDM may be challenging if considering it is not an objective evaluation<sup>9</sup>. Indeed, there are more actors' opinions involved, and, therefore, it has been proposed to assess it from different perspectives: patient's, physician's, and independent observer's one<sup>10</sup>. A combined triangulation of these three viewpoints is needed to optimize the result and reduce individual observation biases into the consultation process<sup>11</sup>. In this regard, even available assessment tools to evaluate SDM can be classified by preferred viewpoint, viz by an external observer, the patient, or the physician<sup>12</sup>.

To date, only a few validated psychometric measures are able to assess SDM from an external point of view, namely the dyadic OPTION (Observing Patient Involvement) scale<sup>13</sup>, and the MAPPIN'SDM measure<sup>14</sup>. On the other hand, the 9-item Shared Decision Making Questionnaire (SDM-Q-9)<sup>15,16</sup> represents the patient-reported gold-standard tool to evaluate SDM, while its physician *alter ego* version is the Shared Decision Making Questionnaire - Physician Version (SDM-Q-Doc), which measures the same SDM features, but from the physician's perspective<sup>17</sup>. Both instruments focus on the decisional process by rating physicians' and patients' behavior in medical encounters in a reliable and feasible administration with only nine items,<sup>12</sup> within a valid and solid psychometric testing, and high acceptance rate<sup>16</sup>.

To date, the SMD-Q-Doc has been translated and validated in numerous languages<sup>18</sup>, including the Dutch version<sup>6</sup>, as well as German<sup>17</sup>, Japanese<sup>19</sup>, Persian<sup>20</sup>, and Spanish<sup>21</sup>, but, to the best of our knowledge, no validation study of the Italian version of SDM-Q-Doc has been conducted yet, thus severely limiting the analysis of SDM in this language<sup>18</sup>.

The aim of our study was to test and assess the psychometric properties of the Italian version of SDM-Q-Doc in a real-world outpatient clinical sample of patients suffering from major psychiatric disorders.

## Materials and methods

### PARTICIPANTS AND PROCEDURE

Participants have been consecutively recruited at the psychiatric outpatient services of the University Hospital "Mater Domini" of Catanzaro (Italy) for 16 months (October 2020-February 2022) and have been evaluated by experienced clinicians according to the Mini International Neuropsychiatric Interview (MINI) with at least a previous 6-month follow-up time. The interviewers were expert clinicians who work in clinical practice and research, and were trained in the administration of the expected neuropsychiatric tests.

The study was carried out with a naturalistic design, without any influence with respect to the therapeutic choices that would have been implemented. We enrolled patients affected by any kind of psychiatric disease according to DSM-5 diagnostic criteria<sup>22</sup>, including schizophrenia spectrum disorders (SSD), bipolar disorder (BD), major depressive disorder (MDD), anxiety disorders, obsessive-compulsive disorder (OCD), personality disorders, and eating disorders (EDs).

We settled the following inclusion criteria for patients: 1) absence of any diagnoses of substance abuse or dependence for a continuative time of more than 6 months; 2) aged between 18 and 65 years; 3) ability to read and understand the study informed consent; 4) chart diagnosis of SSD, BD type I, BD type II, cyclothymia, MDD, dysthymia, anxiety disorders, OCD, personality disorders or EDs according to the DSM-5 criteria<sup>22</sup>; and 5) in clinical remission at the time of the assessment according to a Clinical Global Impression (CGI) score  $\leq 2$ <sup>23</sup>.

We excluded all patients who met the following exclusion criteria: 1) clinical diagnosis of pervasive developmental disorder or autism spectrum disorder according to the DSM-5; 2) difficulty in understanding the research protocol; 3) estimated premorbid IQ <70; 4) personal history of a severe medical or neurological disease that could affect cognitive or social functioning; and 5) medical and psychiatric history that was recent, implausible, or undocumented. No specific inclusion/exclusion criteria were settled for clinicians involved in the study and conducting the visits.

All eligible candidates were informed about the aims and procedures of the study, the voluntariness of participation, anonymity, and safety of personal data, and that no clinical or economic benefits would be given for the participation. A written informed consent was signed before any further step took place. The study protocol was submitted and approved by the local Ethical Committee of University Hospital

Mater Domini at Catanzaro (Italy) “Regione Calabria, sezione Area Centro” before collecting any data. A complete description of the aims and methods was given to each of them before signing the informed consent. The study protocol and procedures complied with the ethical principles set out in the revised version of Helsinki Declaration<sup>24</sup>.

## MEASURES

All participants underwent a comprehensive assessment and clinical evaluation at their follow-up in person visits by means of the following tests: 1) The nine-item physician version of the shared decision making questionnaire (SDM-Q-Doc), filled-up by physicians conducting the visits, and 2) the OPTION Scale, already validated in Italian<sup>25</sup>. Clinicians completed by themselves the SDM-Q-Doc assessment, after the consultation.

The following assessment tools were administered to clinicians and patients respectively, respectively:

The nine-item Shared Decision-Making Questionnaire physician version (SDM-Q-Doc) is a self-reported questionnaire designed to assess physicians' point of view on SDM<sup>17</sup>. The assessment encloses two open-ended questions: [‘Please indicate which health complaint/problem/illness the consultation was about’ and ‘Please indicate which decision was made’] followed by nine multiple-choice questions. Each multiple-choice question describes various aspects of SDM through a statement, and they rate on a 6-point balanced scale ranging from 0 (= ‘completely disagree’) to 5 (= ‘completely agree’). The total score is calculated by summing the score of all nine items, and it is synthesized on a scale ranging between 0 and 45, and a higher score denotes a greater level of perceived SDM from the clinician. Following earlier studies, we rescaled the raw total scores to a 0-100 range<sup>15</sup>. The original version of the SDM-Q-9 was translated into English and Italian, permitting its use in international research<sup>15</sup>.

The OPTION Scale<sup>26</sup>: is a 12 item five-point scale [from 0 (behavior not observed) to 4 (high standard)], so the raw total score ranges from 0 to 48. Scores are normally transformed into a 0-100 score<sup>25</sup>.

In addition, socio-demographic and clinical data were collected for all participants as per chart.

## STATISTICAL ANALYSIS

The Confirmatory Factor Analysis (CFA) was run through the open-source software JASP (JASP, Version 0.16.1, University of Amsterdam, The Netherlands) to better examine the structure of the Italian version of SDM-Q-Doc. Diagonal Weighted Least Squares (DWLS) estimator was used to estimate the

parameters since it provides the best option for categorical or ordered data<sup>27</sup>.

The Tucker-Lewis Index (TLI), the Comparative Fit Index (CFI), the Root Mean Square Error of Approximation (RMSEA), Standardized Root Mean Squared Residual (SRMR) and its chi-square ( $\chi^2/df$ ) were used to evaluate the goodness of adaptation of the data to the proposed model.

For TLI and CFI, values of .90 and above are considered adequate, while values of .95 or above are considered excellent; for RMSEA values of .08 and below are considered adequate and values of .05 or below are considered excellent; for SRMR a cut-off value close to .08 are considered adequate. Values of  $\chi^2/df < 3.0$  are considered good, while values  $< 2.0$  are excellent. The levels of these indices were assessed according to the recommendations of Hu and Bentler<sup>28</sup>.

Regarding the internal consistency, given the renowned limitations to the use of the Cronbach's  $\alpha$ <sup>29,30</sup> due to the very restrictive assumptions it relies on, we assessed it through the McDonald's  $\omega$  total<sup>31</sup>.

We also calculated the SDM-Q-Doc inter-item correlations for each of 9 items. In details, the inter-item correlations provide an estimation of the item redundancy, or rather the degree to which the tool items estimate the same content. Still, inter-item correlations appraise how much scores on one item are related to scores on all other item in the same scale.

Construct validity was determined by correlations between the single items and total scores of the SDM-Q-Doc and the OPTION, considering that correlation coefficients ( $r$ ) greater than .30 are recommended<sup>32</sup>. A  $p < .05$  was considered statistically significant.

## Results

We recruited a total of 369 consecutive patients fulfilling the protocol inclusion/exclusion criteria, with their respective 7 clinical psychiatrists. Of these, 25 patients refused to participate in the study because they did not have the time to complete the assessment ( $n=15$ ); did not sign the informed consent ( $n=8$ ); or for other reasons ( $n=2$ ). Therefore, we reached a 93.2% participation rate, and the final sample was made up of 344 patients, with an average age of  $39.7 \pm 17.9$  years, and a majority of female ( $n=221$ ; 64.2%), non-smoker ( $n=242$ ; 70.3%), single ( $n=193$ ; 56.1%), students ( $n=94$ ; 27.3%), mostly suffering from MDD ( $n=61$ ; 17.7%) and SSD ( $n=59$ ; 21.8%) (table 1).

The CFA showed a very good fit: relative chi-square ( $\chi^2/df$ ) = 3.2, CFI = .99, TLI = .99, RMSEA = .08, and SRMR = .04, suggesting the suitability of the Italian version of SDM-Q-Doc model (figure 1).

The McDonald's  $\omega$  coefficient was .92 for the total score indicating an excellent reliability of the

**Table 1.** Socio-demographic characteristics of the sample.

		Total Sample	
		n=344	
Age <sup>a</sup>		39.7	(17.9)
Years of education <sup>a</sup>		11.5	(3.4)
Gender <sup>b</sup>	Men	123	(35.8)
	Women	221	(64.2)
Smoker <sup>b</sup>	Yes	102	(29.7)
	No	242	(70.3)
Civil Status <sup>b</sup>	Single	193	(56.1)
	Married	136	(39.5)
	Divorced	11	(3.2)
	Widow	4	(1.2)
Occupation <sup>b</sup>	Student	94	(27.3)
	Unemployed	75	(21.8)
	Office worker	72	(20.9)
	Housewife	33	(9.6)
	Self-employer	32	(9.3)
	Retired	28	(8.1)
	Disable	10	(2.9)
Diagnosis <sup>b</sup>	Major Depressive Disorder	61	(17.7)
	Schizophrenia Spectrum Disorder	59	(17.2)
	Anxiety Disorder	51	(14.8)
	Anorexia Nervosa	44	(12.8)
	Bipolar Disorder	33	(9.6)
	Bulimia Nervosa	33	(9.6)
	Binge Eating Disorder	26	(7.6)
	Eating Disorders Not Otherwise Specified	15	(4.4)
	Obsessive-Compulsive Disorder	11	(3.2)
	Personality Disorder	11	(3.2)

<sup>a</sup> Data are presented as means (SD); <sup>b</sup> Data are presented as frequencies (%).

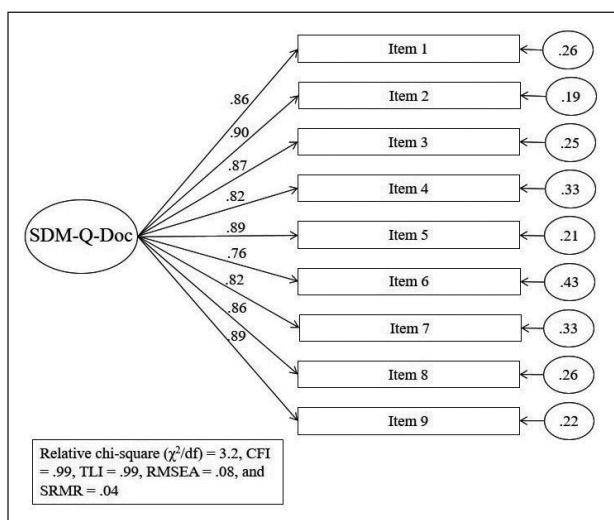

**Figure 1.** Confirmatory Factor Analysis of the Italian version of the SDM-Q-Doc.

questionnaire. Further, inter-item correlations ranged from .390 to .703, with a mean of .556 (table 2).

Finally, regarding convergent validity, low and moderate correlations emerged between the items and the total scores of OPTION and SDM-Q-Doc (table 3).

## Discussion

In this cross-sectional study, we enrolled a large clinical sample aiming to validate the Italian version of the SDM-Q-Doc, a psychometrically solid tool which assesses the SDM process from the physician’s perspective. We tested the psychometric properties of the scale, already validated and used in several languages<sup>17,19</sup>, demonstrating excellent reliability, sound internal consistency, and good

**Table 2.** Inter-item correlations of the SDM-Q-Doc.

	Item 1	Item 2	Item 3	Item 4	Item 5	Item 6	Item 7	Item 8	Item 9
Item 1	-								
Item 2	.580	-							
Item 3	.547	.618	-						
Item 4	.543	.537	.638	-					
Item 5	.597	.611	.670	.661	-				
Item 6	.452	.547	.508	.390	.465	-			
Item 7	.545	.597	.546	.460	.536	.654	-		
Item 8	.511	.703	.557	.477	.581	.604	.641	-	
Item 9	.588	.686	.560	.500	.647	.436	.490	.680	-

\* All correlations are statistically significant with a *p*-value <.001.

**Table 3.** Correlation of single items and total scores of the SDM-Q-Doc and OPTION Scale.

OPTION	SDM-Q-Doc									Total
	Item 1	Item 2	Item 3	Item 4	Item 5	Item 6	Item 7	Item 8	Item 9	
Item 1	.169**	.141**	.157**	.187***	.256***	.078	.088	.116*	.087	.185**
Item 2	.166**	.192***	.172**	.155**	.205***	.166**	.129*	.189***	.172**	.221***
Item 3	.223***	.116*	.190***	.092	.174**	.224***	.150**	.214***	.253***	.236***
Item 4	.124*	.106	.103	.080	.035	.123*	.074	.084	.060	.150**
Item 5	.146**	.095	.110*	.137*	.132*	.108*	.071	.122*	.097	.139**
Item 6	.149**	.095	.081	.175**	.152**	.150**	.137*	.223***	.123*	.199***
Item 7	.077	.113*	.091	.079	.194***	.107*	.171**	.136*	.137*	.179**
Item 8	.113*	.061	.227***	.120*	.248***	.115*	.179**	.137*	.121*	.211***
Item 9	.119*	.052	.075	.001	.102	.115*	.055	.103	.028	.094
Item 10	.081	.189***	.138*	.068	.114*	.224***	.180**	.242***	.093	.225***
Item 11	.116*	.104	.111*	.076	.099	-.010	-.033	.089	.039	.073
Item 12	.070	.073	.077	.004	.078	.049	-.033	.059	.065	.056
<b>Total</b>	<b>.229***</b>	<b>.183**</b>	<b>.202***</b>	<b>.178***</b>	<b>.233***</b>	<b>.199***</b>	<b>.142**</b>	<b>.205***</b>	<b>.159**</b>	<b>.266***</b>

OPTION: observing patient involvement scale; SDM-Q-Doc: the Shared Decision Making Questionnaire-Physician Version.  
 \* *p*-value <.05; \*\* *p*-value <.01; \*\*\* *p*-value <.001.

and acceptable-to-good convergent validity for the Italian translation of the scale as well. Moreover, we found an elevated level of acceptance by the physicians who were approached for the study. Finally, we also confirmed the hypothesized factorial structure of one dimension, supporting factorial validity, whereas several low loadings and residual correlations simultaneously suggest substantial construct heterogeneity.

Overall, our results are in line with previous findings from the original German version of SDM-Q-Doc by Scholl et al., who developed and validated the physician’s perception of the SDM process adapting

the already largely used SDM-Q-9<sup>17</sup>. The decision to develop and validate an assessment tool that focuses on the doctor’s point of view in SDM arises from the deep nature of the therapeutic relationship and the shared clinical decision<sup>33</sup>. In fact, since it is a two-actor relationship, the involvement of the patient’s point of view alone appears to be lacking in one component, which is therefore filled with the SDM-Q-Doc. For instance, the availability of the double-side instruments in Italian language to comprehensively clinically assess the SDM finally fills the gap on the topic, and such eventuality should be encouraged in other languages as well<sup>18,34</sup>.

As already applied in our previous work<sup>16</sup>, in this study we excluded patients suffering from substance abuse or dependence, severe medical or neurological diseases potentially affecting affect cognitive or social functioning, and recent or unclear psychiatric history, in order to avoiding possible bias and confounding factors with respect to the doctor-patient relationship and therefore make the results implausible<sup>34,35</sup>. Certainly, in the future, it will be interesting to explore SDM also in patients suffering from these disorders, with recent access to psychiatric services, or following them over time to evaluate the evolution of the SDM in their therapeutic path.

Regarding the enrolled sample size, our final sample is larger than similar validation studies of the SDM-Q-Doc in German<sup>17</sup>, Japanese<sup>19</sup>, Dutch<sup>6</sup>, and other languages<sup>18</sup>. This point strengthens our results, but the data is even more interesting when compared to the number of clinicians involved. In fact, our large sample foresees the involvement of only 7 clinicians, greatly reducing the inter-rater variability. If on the one hand the reduced number of evaluators could be seen as a limitation potentially able to invalidate the variability of the answers collected, on the other hand it increases the internal consistency and inter-rater reliability, guaranteeing greater uniformity of training and clinical judgment, overall balanced by patients' OPTION scale assessments. Notably, we touched a 93.2% acceptance rate, thus confirming a high level of completion rate for all items, and in line with what has been reached in other languages<sup>6,17,36</sup>.

The Italian version of SDM-Q-Doc showed a high internal consistency value (McDonald  $\omega$  coefficient was .92), elevated items discrimination, and an adequate inter-item correlation, thus confirming a good consistency of the translated tool. Indeed, our findings are similar and even better if compared to other SDM-Q-Doc translated versions including Dutch (Cronbach's  $\alpha$  of 0.88)<sup>6</sup>, German (Cronbach's  $\alpha$  of .88)<sup>17</sup>, and Japanese (Cronbach's  $\alpha$ = 0.87,  $\omega$ = 0.88)<sup>19</sup> versions, highlighting a similar scale reliability for our version. We also found low and moderate correlations between the single items and the total scores of SDM-Q-Doc and OPTION scale, strengthening the data in favor of convergent validity between the instruments.

Consistently to the original German version of the scale<sup>17</sup>, also we reached satisfactory results testing all the items of the scale without the need to test different single-factor models excluding specific SDM-Q-Doc items. The same factor analysis was also confirmed by the Japanese translation with the enrollment of 130 patients and 23 doctors<sup>19</sup>, while the Dutch version, with 43 psychiatrists and 201 patients, obtained a better index excluding items 1 and 9<sup>6</sup>, shining light on the hypothesis that the result may be influenced by the sample size, and even more by the number of raters involved.

Compared to different neurocognitive or psychological assessment, the SDM evaluation scale provide both a theoretical research value and a concrete application into everyday clinical practice. Indeed, the concurrent use of both SDM-Q-9 and SDM-Q-Doc allows the global assessment of the perspectives of both shareholders in the SDM process. Moreover, in the light of the feasibility and quick-filling of the instruments, they can easily be used in trials as well as in clinical practice for a real-time analysis of the effectiveness of different interventions on the implementation of SDM and as a quality indicator of health service assessments<sup>17</sup>.

#### LIMITATIONS AND STRENGTHS

Interpreting our results, we acknowledge both some limitations and strengths. First, the cross-sectional study design does not allow to draw longitudinal and prospective conclusions. Indeed, considering the SDM as a lively and moving process based on personal relationships and human interactions, it should be desirable to conduct dynamic follow-up studies to explore its evolution over time. Second, the huge sample size diagnostic variability carries on a broad spectrum of clinical severity, duration of disease and treatment management choices which could influence SDM making, making the final results very heterogeneous. However, this wide variability did not affect the validations results, neither the inter-item correlations, thus demonstrating the tool's applicability and reproducibility even in each setting of a real-world clinical sample. This consideration stands in line with current literature data reporting a wide clinical area application for SDM-Q-Doc and a range of its use in different health care settings to evaluate different interventions<sup>36</sup>. Finally, we did not provide a test-retest reliability calculation. Nonetheless, we must consider that the reproducibility over time, also known as test-retest reliability, is one of several statistical approaches to evaluate and measure reliability, which embrace also internal consistency, inter-rater reliability and convergent validity compared to the gold-standard tool (i.e., the OPTION scale), that we run. Certainly, internal consistency estimates how the single items results correlate with each other<sup>37</sup>, that we demonstrated to be more than acceptable in our findings.

On the other hand, we highlight some important and peculiar strengths in our study. First, we reached a large and satisfactory final sample size, enrolling 344 participants and recording a very high participation rate (93.2%). This value is much higher than similar studies<sup>6,16,17,36</sup>, and, even superior to the minimal recommended limit to validate an assessment tool. On this regard, indeed, most used recommendations for minimum sample size suggest ranging from 2 to 20

subjects per tool item<sup>38</sup>, with a total minimum number of 100 to 250 subjects anyway<sup>39</sup>. Furthermore, we also followed guidance proposed by Comrey and Lee (1992)<sup>40</sup>: 100 participants=poor, 200=fair, 300=good, 500=very good,  $\geq 1000$ =excellent. Thus, with a total of 344 participants with a 9-items tool, according to the described recommendations, the enrolled sample can be considered more than adequate to validate the scale.

Second, we used the OPTION scale, widely recognized as gold-standard instrument to explore SDM from external viewpoint, as a proper assessment to test the convergent validity<sup>41</sup>. Indeed, considering the lack of an alternative self-assessment to measure SDM by clinicians, we applied an already validated technique to overcome this limitation<sup>16,42</sup>. Finally, we run the study in a real-world outpatients clinical setting, enrolling consecutive patients without any specific exclusion criteria, thus presenting an easily reproducible trial with a large sample made up of patients suffering from a range of severe psychiatric disorders, with the aim of making the results generalizable.

## Conclusions

Our results confirm a very good fit, a high reliability, and excellent psychometric properties of the Italian version of SDM-Q-Doc, largely equivalent to the original and other language validation versions. Indeed, the Italian version of SDM-Q-Doc showed a robust internal consistency, even when compared to OPTION scale and tested in a clinical sample of patients affected by major psychiatric disorders. Therefore, we can assume that SDM-Q-Doc demonstrated to be a feasible, reliable, and easy-to-use tool to assess SDM in Italian clinical settings.

*Conflict of interests:* the authors have no conflict of interests to declare.

## References

- Makoul G, Clayman ML. An integrative model of shared decision making in medical encounters. *2006*; 60: 301-12.
- Berger Z, Galasinski D, Scalia P, Dong K, Blunt HB, Elwyn G. The submissive silence of others: examining definitions of shared decision making. *Patient Educ Couns* 2022; 105: 1980-7.
- Kon AA. The shared decision-making continuum. *JAMA* 2010; 304: 903.
- Elwyn G, Laitner S, Coulter A, Walker E, Watson P, Thomson R. Implementing shared decision making in the NHS. *BMJ* 2010; 341: c5146-c5146.
- Chewning B, Bylund CL, Shah B, Arora NK, Gueguen JA, Makoul G. Patient preferences for shared decisions: a systematic review. *Patient Educ Couns* 2012; 86: 9-18.
- Rodenburg-Vandenbussche S, Pieterse AH, Kroonenberg PM, et al. Dutch translation and psychometric testing of the 9-Item Shared Decision Making Questionnaire (SDM-Q-9) and Shared Decision Making Questionnaire-Physician Version (SDM-Q-Doc) in primary and secondary care. *PLoS One* 2015; 10: e0132158.
- Stiggelbout AM, Van der Weijden T, De Wit MPT, et al. Shared decision making: really putting patients at the centre of healthcare. *BMJ* 2012; 344: e256.
- de Filippis R, De Fazio P, Gaetano R, et al. Current and emerging long-acting antipsychotics for the treatment of schizophrenia. *Expert Opin Drug Saf* 2021; 20: 771-90.
- Charles C, Gafni A, Whelan T. Shared decision-making in the medical encounter: what does it mean? (or it takes at least two to tango). *Soc Sci Med* 1997; 44: 681-92.
- Légaré F, Ratté S, Stacey D, et al. Interventions for improving the adoption of shared decision making by healthcare professionals. *Cochrane Database Syst Rev* 2010; (5): CD006732.
- Mead N, Bower P. Patient-centredness: a conceptual framework and review of the empirical literature. *Soc Sci Med* 2000; 51: 1087-110.
- Scholl I, Koelewijn-van Loon M, Sepucha K, et al. Measurement of shared decision making. A review of instruments. *Z Evid Fortbild Qual Gesundheitswes* 2011; 105: 313-24.
- Melbourne E, Roberts S, Durand M, Newcombe R, Légaré F, Elwyn G. Dyadic OPTION: measuring perceptions of shared decision-making in practice. *Patient Educ Couns* 2011; 83: 55-7.
- Kasper J, Hoffmann F, Heesen C, Köpke S, Geiger F. MAPPIN'SDM--the multifocal approach to sharing in shared decision making. *PLoS One* 2012; 7: e34849.
- Kriston L, Scholl I, Hölzel L, Simon D, Loh A, Härter M. The 9-item Shared Decision Making Questionnaire (SDM-Q-9). Development and psychometric properties in a primary care sample. *Patient Educ Couns* 2010; 80: 94-9.
- de Filippis R, Aloï M, Piliéci AM, et al. Psychometric properties of the 9-item Shared Decision-Making Questionnaire (SDM-Q-9): validation of the Italian version in a large psychiatric clinical sample. *Clin Neuropsychiatry J Treat Eval* 2022; 19: 264-71.
- Scholl I, Kriston L, Dirmaier J, Buchholz A, Härter M. Development and psychometric properties of the Shared Decision Making Questionnaire--physician version (SDM-Q-Doc). *Patient Educ Couns* 2012; 88: 284-90.
- SDM-Q-9 / SDM-Q-Doc. The 9-item Shared Decision Making Questionnaire. Available from: <https://bit.ly/3Is9jES> [last accessed 19 May 2023].
- Goto Y, Miura H, Son D, et al. Association between physicians' and patients' perspectives of shared decision making in primary care settings in Japan: the impact of environmental factors. *PLoS One* 2021; 16: e0246518.
- Nejati B, Lin C-C, Imani V, et al. Validating patient and physician versions of the shared decision making questionnaire in oncology setting. *Heal Promot Perspect* 2019; 9: 105-14.
- Calderón C, Ferrando PJ, Carmona-Bayonas A, et al. Validation of SDM-Q-Doc Questionnaire to measure shared decision-making physician's perspective in oncology practice. *Clin Transl Oncol* 2017; 19: 1312-9.
- American Psychiatric Association. Diagnostic and statistical manual of mental disorders. 5th ed. Washington, DC: American Psychiatric Association Publishing, 2013.
- Guy W. Clinical Global Impression (CGI). Guy W, editor. ECDEU Assessment Manual for Psychopharmacology. Rockville, Maryland: Department of Health, Education, and Welfare, 1976.
- World Medical Association. World Medical Association Declaration of Helsinki: ethical principles for medical research involving human subjects. *JAMA* 2013; 310: 2191.
- Goss C, Fontanesi S, Mazzi M, et al. Shared decision mak-

- ing: the reliability of the OPTION Scale in Italy. *Patient Educ Couns* 2007; 66: 296-302.
26. Elwyn G, Hutchings H, Edwards A, et al. The OPTION Scale: measuring the extent that clinicians involve patients in decision-making tasks. *Health Expect* 2005; 8: 34-42.
  27. Buck B, Browne J, Gagen EC, Penn DL. Hostile attribution bias in schizophrenia-spectrum disorders: narrative review of the literature and persisting questions. *J Ment Heal* 2023; 32: 132-49.
  28. Hu L, Bentler PM. Cutoff criteria for fit indexes in covariance structure analysis: conventional criteria versus new alternatives. *Struct Equ Model A Multidiscip J* 1999; 6: 1-55.
  29. McNeish D. Thanks coefficient alpha, we'll take it from here. *Psychol Methods* 2018; 23: 412-33.
  30. Trizano-Hermosilla I, Alvarado JM. Best alternatives to Cronbach's Alpha Reliability in realistic conditions: congeneric and asymmetrical measurements. *Front Psychol* 2016; 7: 769.
  31. Revelle W, Zinbarg RE. Coefficients Alpha, Beta, Omega, and the glb: comments on Sijtsma. *Psychometrika* 2009; 74: 145-54.
  32. McGraw KO, Wong SP. Forming inferences about some intraclass correlation coefficients. *Psychol Methods* 1996; 1: 30-46.
  33. Ortiz SE, Rosenthal MB. Medical marketing, trust, and the patient-physician relationship. *JAMA* 2019; 321: 40.
  34. Luciano M, Sampogna G, Del Vecchio V, et al. When does shared decision making is adopted in psychiatric clinical practice? Results from a European multicentric study. *Eur Arch Psychiatry Clin Neurosci* 2020; 270: 645-53.
  35. Carrà G, Johnson S, Crocamo C, et al. Psychosocial functioning, quality of life and clinical correlates of comorbid alcohol and drug dependence syndromes in people with schizophrenia across Europe. *Psychiatry Res* 2016; 239: 301-7.
  36. Doherr H, Christalle E, Kriston L, Härter M, Scholl I. Use of the 9-item Shared Decision Making Questionnaire (SDM-Q-9 and SDM-Q-Doc) in Intervention studies. A systematic review. *PLoS One* 2017; 12: e0173904.
  37. Cook DA, Beckman TJ. Current concepts in validity and reliability for psychometric instruments: theory and application. *Am J Med* 2006; 119: 166.e7-166.e16.
  38. Hair J, Anderson R, Tatham R, Black W. *Multivariate data analysis: with readings*. London: Pearson College, 1995.
  39. Anthoine E, Moret L, Regnault A, Sébille V, Hardouin J-B. Sample size used to validate a scale: a review of publications on newly-developed patient reported outcomes measures. *Health Qual Life Outcomes* 2014; 12: 2.
  40. Comrey AL, Lee HB. *A first course in factor analysis*. 2nd ed. Mahwah, NJ: Lawrence Erlbaum Associates, 1992.
  41. Melbourne E, Sinclair K, Durand M-A, Légaré F, Elwyn G. Developing a dyadic OPTION scale to measure perceptions of shared decision making. *Patient Educ Couns* 2010; 78: 177-83.
  42. Scholl I, Kriston L, Dirmaier J, Härter M. Comparing the nine-item Shared Decision-Making Questionnaire to the OPTION Scale - an attempt to establish convergent validity. *Heal Expect* 2015; 18: 137-50.

---

Corresponding author:  
Prof. Pasquale De Fazio  
Psychiatry Unit  
Department of Health Sciences  
University Magna Graecia of Catanzaro  
Viale Europa  
88100 Catanzaro, Italy  
E-mail: defazio@unicz.it